

mini-BioProducer™ 12 Steamer

Autoclavable, Gamma Irradiated
Hollow Fiber Cartridges
Large Capacity — Superior Yield



The **mini-BioProducer™ Steamer** hollow fiber membrane products incorporates our latest glycerin-free, heat resistant, low extractable modified polyethersulfone (m-PES) membrane technology. All **Steamer** products are gamma irradiated and ready to use without any tedious pre-rinse. The **Steamer HF** cartridges are the product of choice for perfusion/ATF™ applications. They can be repetitively autoclaved in an ATF™ perfusion unit or as a stand alone HF cartridge. The **mini-BioProducer™ Steamer** is also available as a single use assembly for crossflow perfusion applications.

The extractable level for the **mini-BioProducer™ Steamer** is approximately 80x less than a glycerin conditioned membrane or at sheet cassette. See [Extractables Flush Analysis](#). After a quick buffer conditioning the HF cartridge is ready to use, or to be or autoclaved. For autoclaving directions, please see the [Steamer Validation Guide](#).

The **mini-BioProducer™ Steamer** hollow fiber cartridges are designed for small to medium scale production and are the perfect tools for scale up studies to **Steamer BioProducer™** multi-cartridge systems. With a surface area of 0.61 m², the **mini-BioProducer™ 12 Steamer** HF cartridge can accommodate batch volumes between 5L and 50L with a typical permeate flow rate of 18-37 L/hr for ultrafiltration applications and 12-24 L/hr for microfiltration applications.

Offered in the same path length as all other WaterSep 12" hollow fiber cartridges, the **mini-BioProducer™ 12 Steamer** HF cartridge which makes scale up and scale down easy and predictable.

The **mini-BioProducer™ 12 Steamer** cartridges offer true ready to use crossflow filtration that is:

- Gamma irradiated - ready to use - no pre-rinse required.
- Humectant free - 80x less extractables,
- Free of time-consuming cleaning validation.
- At a reduced risk of cross contamination.
- Consistent, membrane performance batch to batch.
- Self-contained and requires no assembly, no expensive hardware and no membrane installation.
- Significantly less expensive than traditional cassette formats.
- Every HF cartridge is integrity tested and has an individual lot number for easy traceability.

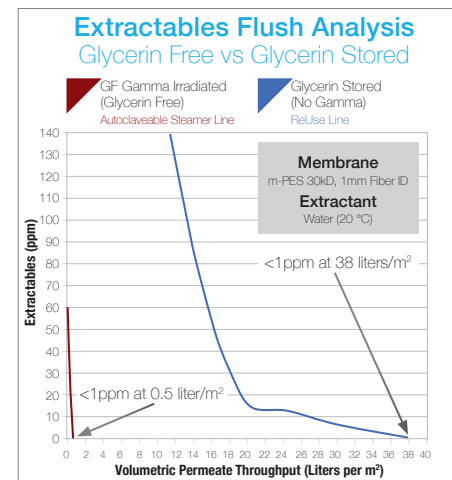

TYPICAL APPLICATIONS

- **Cell perfusion** with an ATF™ system or conventional pump operated crossflow perfusion system. Bioreactor and **Steamer** hollow fiber assembly can be autoclaved simultaneously.
- Production scale **aseptic operations** or any other sterile application requiring autoclaving.
- Rapid clarification of volumes ranging from 5L to 50L of **cell culture, fermentation solutions and virus/vaccine suspensions**.
- Concentration and diafiltration of **monoclonal antibodies, enzymes, blood components and other proteins**.

mini-BioProducer™ 12 Steamer

ORDERING INFORMATION

Place orders online at www.watersep.net, or email purchase orders to orders@watersep.net, sales order confirmation to follow.

mini-BioProducer™ 12 Steamer HF Cartridge

0.5 mm ID

AU XXX 05MPR12 S3, 3/pkg

AU XXX 05MPR12 S6, 6/pkg

1.0 mm ID

AU XXX 10MPR12 S3, 3/pkg

AU XXX 10MPR12 S6, 6/pkg

2.0 mm ID*

AU XXX 20MPR12 S3, 3/pkg

AU XXX 20MPR12 S6, 6/pkg

*Available in 10K, 50K, 300K-750K and 0.1 μm - 0.45 μm

Replace XXX with:

003 for 3K	050 for 50K	750 for 750K
005 for 5K	100 for 100K	910 for 0.1 μm
010 for 10K	300 for 300K	920 for 0.2 μm
030 for 30K	500 for 500K	945 for 0.45 μm

SPECIFICATIONS

Cartridge Dimensions

2.70" (6.86 cm) x 15.00" (38.10 cm)

Membrane Surface Area

6.6 ft² (0.61 m²)

Molecular Weight Cut-off

3K, 5K, 10K, 30K, 50K, 100K, 300K, 500K, 750K

Membrane Pore Size

0.1 μm , 0.2 μm and 0.45 μm

Fiber ID

0.5 mm, 1.0 mm, 2.0 mm

MATERIALS OF CONSTRUCTION

The cartridge as assembled is USP Class VI compliant.

Membrane

Modified Polyethersulfone (m-PES)

Housing

White Polysulfone

Encapsulant

Medical Grade Epoxy

CONNECTIONS

Feed/Retentate

1.5" TC Standard Sanitary Fitting

Permeate

0.75" TC Standard Sanitary Fitting

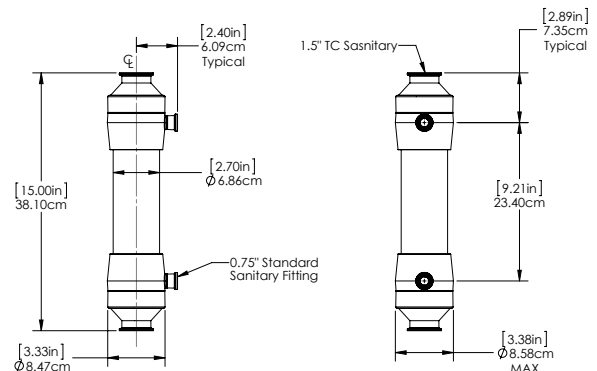

Technical Support: experttalk@watersep.net
or call 508.970.0089 x 204.