

Investigator12 Steamer

Autoclavable, Gamma Irradiated Hollow Fiber Cartridges

Easy and Reliable



Investigator Steamer hollow fiber membrane products incorporate our latest glycerin free low extractables, heat resistant modified polyethersulfone (m-PES) membrane technology. All **Steamer** products are gamma irradiated and ready to use without any tedious pre-rinse. The **Steamer** HF cartridges are the product of choice for perfusion applications. They can be repetitively autoclaved in an ATF perfusion unit or as a stand alone HF cartridge. Please contact us for the correct **Steamer** product for ATF 2-10 models at experttalk@WaterSep.net. The **Investigator Steamer** is also available as a single use assembly for crossflow perfusion applications.

The extractables level for the **Investigator Steamer** is approximately 80x less than a glycerin conditioned membrane, see [Extractables Flush Analysis](#). After a quick buffer conditioning the HF cartridge is ready to be used or autoclaved. For autoclaving directions, please see the [Steamer Validation Guide](#) at www.WaterSep.net.

The **Investigator12 Steamer** crossflow hollow fiber membrane cartridges are positioned between the pilot scale **Researcher Steamer** and the production scale **mini-BioProducer Steamer** cartridges. With a membrane surface area of 1300 cm², the **Investigator12 Steamer** can accommodate batch volumes that range from 1L to 6L with a typical permeate flow rate of 3.9-7.8 L/hr for ultrafiltration applications and 2.6-5.2 L/hr for microfiltration applications.

The **Investigator12 Steamer** hollow fiber cartridge products are in most applications superior to conventional techniques, like centrifugation, depth filters, cassette crossflow systems or dialysis bags.

The **Investigator12 Steamer** cartridges offer true ready to use crossflow filtration that is:

- Gamma irradiated - ready to use - no rinse.
- Humectant free - 80% less extractables, see [Extractables Flush Analysis](#).
- Free of time-consuming cleaning validation.
- At a reduced risk of cross contamination.
- Consistent, membrane performance batch to batch.
- Self-contained and requires no assembly, no expensive hardware and no membrane installation.
- Significantly less expensive than traditional cassette formats.
- Offered in the same path length as all other WaterSep 12" (30 cm) hollow fiber cartridges for exact and predictable scale up and scale down.
- Every HF cartridge is integrity tested and has an individual lot number for easy traceability.

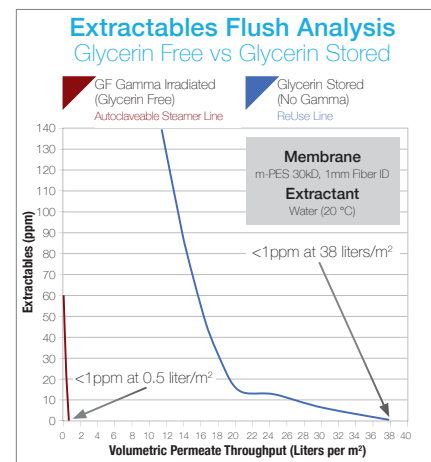

TYPICAL APPLICATIONS

- **Cell perfusion** with an ATF system or conventional pump operated perfusion. (Bioreactor and **Steamer** hollow fiber assemblies can be autoclaved simultaneously.)
- Pilot scale **aseptic/sterile UF-MF applications** where autoclaving is required.
- Rapid clarification of volumes ranging from 1L to 6L of **cell culture, fermentation solutions and virus/vaccine suspensions**.
- Concentration and diafiltration of **monoclonal antibodies, enzymes, blood components, other proteins, and gene therapy products**.

Investigator12 Steamer

ORDERING INFORMATION

Place orders online at www.watersep.net, or email purchase orders to orders@watersep.net, sales order confirmation to follow.

Investigator12 Steamer HF Cartridge

0.5 mm ID
AU XXX 05INV12 S3, 3/pkg
AU XXX 05INV12 S6, 6/pkg

1.0 mm ID
AU XXX 10INV12 S3, 3/pkg
AU XXX 10INV12 S6, 6/pkg

2.0 mm ID*
AU XXX 20INV12 S3, 3/pkg
AU XXX 20INV12 S6, 6/pkg
*Available in 10K, 30K, 50K, 300K - 750K and 0.1 μm - 0.45 μm

Replace XXX with:

003 for 3K	050 for 50K	750 for 750K
005 for 5K	100 for 100K	910 for 0.1 μm
010 for 10K	300 for 300K	920 for 0.2 μm
030 for 30K	500 for 500K	945 for 0.45 μm

SPECIFICATIONS

Cartridge Dimensions
1.32" (3.34 cm) x 12.01" (30.50 cm)

Membrane Surface Area
1.40 ft² (0.13 m²)

Molecular Weight Cut-off
3K, 5K, 10K, 30K, 50K, 100K, 300K, 500K, 750K

Membrane Pore Size
0.1 μm , 0.2 μm and 0.45 μm

Fiber ID
0.5 mm, 1.0 mm, 2.0 mm

MATERIALS OF CONSTRUCTION

The cartridge as assembled is USP Class VI compliant.

Membrane:
Modified Polyethersulfone (m-PES)

Housing:
White Polysulfone

Encapsulant:
Epoxy

CONNECTIONS

Feed/Retentate
1.5" TC Standard Sanitary Fitting

Permeate
0.5" TC Standard Sanitary Fitting

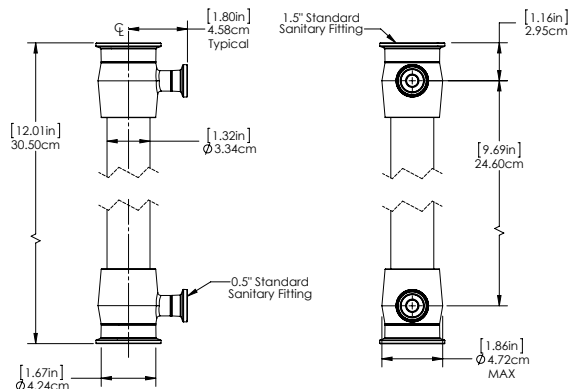

Technical Support: experttalk@watersep.net
or call 508.970.0089 x 204.